

Alternative Fuel Service (AFS) Ball Valves

BU Series

Features

- ⦿ Working pressures up to 6000 psig (413 bar)
- ⦿ Working temperature: -40 to 250°F (-40 to 121°C)
- ⦿ High flow-Cv from 4.0 to 13.8
- ⦿ Low-temperature fluorocarbon material provides sealing capability over full temperature range
- ⦿ Spring-loaded seat provides leak-tight integrity in both low-and high-pressure systems and reduces seat wear from pressure surges
- ⦿ A variety of end connections available
- ⦿ Low operating torque
- ⦿ All wetted components are compatible with hydrogen and compressed natural gas (CNG)
- ⦿ No packing adjustment required
- ⦿ Bi-directional flow
- ⦿ Options for handle colors
- ⦿ Pneumatic actuators available
- ⦿ Each valve is leak tested with Nitrogen or compressed air at working pressure to meet a requirement of no visible leak
- ⦿ Field repairable with seal kit
- ⦿ ECE R110 type approval available

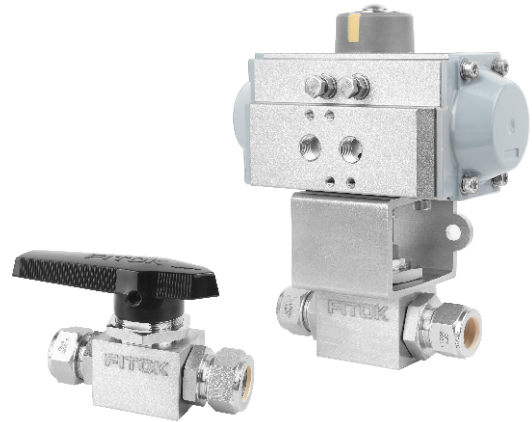

Ball Valves
Plug Valves

Pressure VS Temperature Ratings

End Connection	FITOK Tube Fitting			Female Pipe	
	3/8, 1/2 in., 12 mm	3/4 in., 16 mm	1 in.	3/8, 1/2 in.	3/4 in.
Temperature °F (°C)	Working Pressure, psig (bar)				
-40 (-40) ~ 250 (121)	6000 (414)	5800 (400)	4700 (324)	6000 (414)	6000 (414)

Note: Ratings are based on valves of standard materials.

Standard Materials of Construction

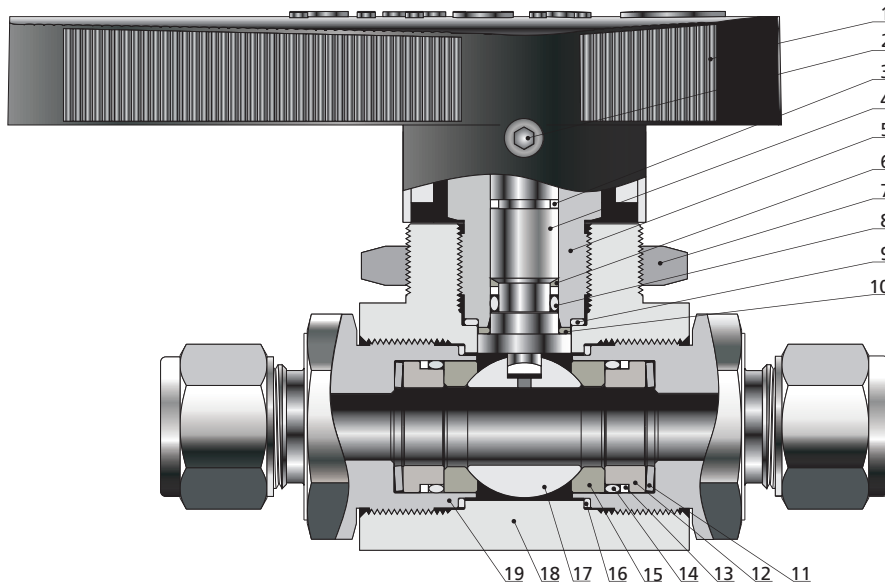

Item	Component	Material/ASTM Standard
1	Handle	Nylon with stainless steel insert
2	Set screw	Zinc-plated carbon steel
3	<i>Guide ring</i>	<i>PTFE/D1710</i>
4	<i>Stem</i>	<i>316 SS/A479</i>
5	<i>Packing bolt</i>	<i>316 SS/A479</i>
6	<i>Stem backup ring</i>	<i>PEEK</i>
7	<i>Lock nut</i>	<i>316 SS/A479</i>
8	<i>Stem O-ring</i>	<i>Low-temperature fluorocarbon</i>
9	<i>Packing bolt washer</i>	<i>Silver-plated 316 SS/A269</i>
10	<i>Thrust washer</i>	<i>PEEK</i>
11	<i>Coned-disc spring</i>	<i>316 SS/A240</i>
12	<i>Seat gland</i>	<i>316 SS/A479</i>
13	<i>Seat backup ring</i>	<i>PTFE/D1710</i>
14	<i>Seat O-ring</i>	<i>Low-temperature fluorocarbon</i>
15	<i>Seat</i>	<i>PEEK</i>
16	<i>End connection gasket</i>	<i>Silver-plated 316 SS/A269</i>
17	<i>Ball</i>	<i>316 SS/A479</i>
18	<i>Body</i>	<i>316 SS/A479</i>
19	<i>End connection</i>	<i>316 SS/A479</i>
	<i>Lubricant</i>	<i>PTFE-based</i>

Note: Wetted components listed in italics.

Dimensions

Dimensions in in. (mm) are for reference only and subject to change.

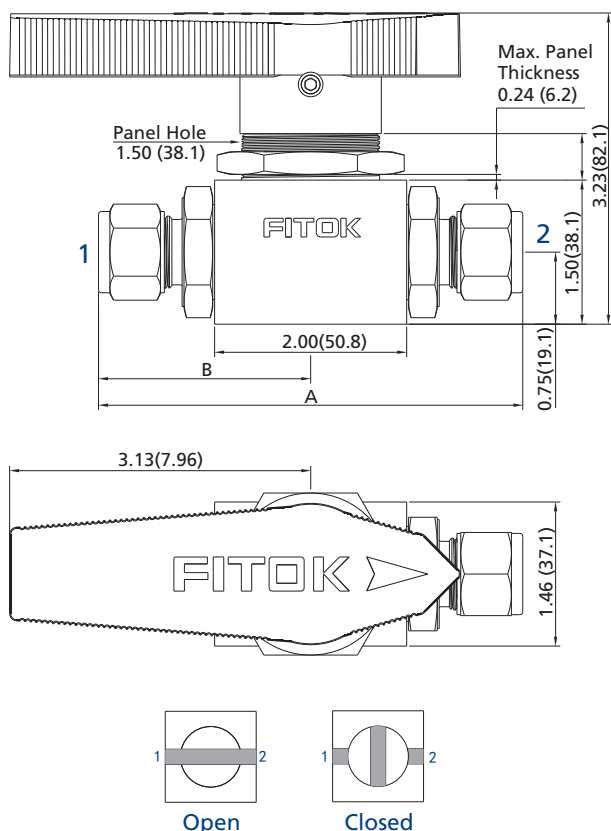

Ordering Number	Connection ^① Type and Size	Cv	Orifice in. (mm)	Dimensions in. (mm)	
				A	B
BUSS-ML10-P12	10 mm FITOK	5.2	0.31 (7.9)	4.21 (107)	2.11 (53.5)
BUSS-ML12-P12	12 mm FITOK	5.2	0.41 (10.3)	4.42 (112.2)	2.21 (56.1)
BUSS-ML16-P12	16 mm FITOK	12.4	0.47 (12.0)	4.42 (112.3)	2.21 (56.2)
BUSS-FL6-P12	3/8" FITOK	4.0	0.28 (7.1)	4.20 (106.6)	2.10 (53.3)
BUSS-FL8-P12	1/2" FITOK	7.2	0.41 (10.3)	4.40 (111.8)	2.20 (55.9)
BUSS-FL12-P12	3/4" FITOK	7.1	0.47 (12.0)	4.50 (114.3)	2.46 (62.5)
BUSS-FL16-P12 ^②	1" FITOK	6.5	0.47 (12.0)	4.93 (125.1)	2.25 (57.1)
BUSS-FNS6-P12	3/8" Female NPT	11.0	0.47 (12.0)	4.01 (102)	2.00 (50.8)
BUSS-FNS8-P12	1/2" Female NPT	13.8		4.01 (102)	2.00 (50.8)
BUSS-FNS12-P12	3/4" Female NPT	7.8		4.13 (105)	2.06 (52.3)
BUSS-FRT8-P12	1/2" Female BSPT	13.8		4.01 (102)	2.00 (50.8)

Note: Dimensions shown with FITOK tube fitting nuts finger-tight.

① Valves can be ordered with two different end connections. Contact FITOK Group or our authorized distributors.

② Not recommended for panel mounting; not available with pneumatic actuator.

CNG/NGV Application

ECE R110 Manual Service Valve Type Approval

Classification: Class 0

Temperature: -40 to 248°F (-40 to 120°C)

Pressure: 3370 psig (260 bar)

To order, add **-R110** to the valve ordering number.

Example: BUSS-ML12-P12-**R110**

Seal kit for field replacement is available, see "Seal Kits".

Seal Kits

Seal Kit Name	Seal Kit Ordering Number	Seal Kit Content
Seat seal kit	SS-BU-P-SE	Seat, seat backup ring, seat O-ring, coned-disc spring, end connection gasket, instructions.
Stem and seat seal kit	SS-BU-P	Guide ring, stem backup ring, stem O-ring, packing bolt washer, thrust washer, seat, seat backup ring, seat O-ring, coned-disc spring, end connection gasket, instructions

Ordering Number Description

BUSS – ML12 – FL12 – P12 – OSHQL – SF2

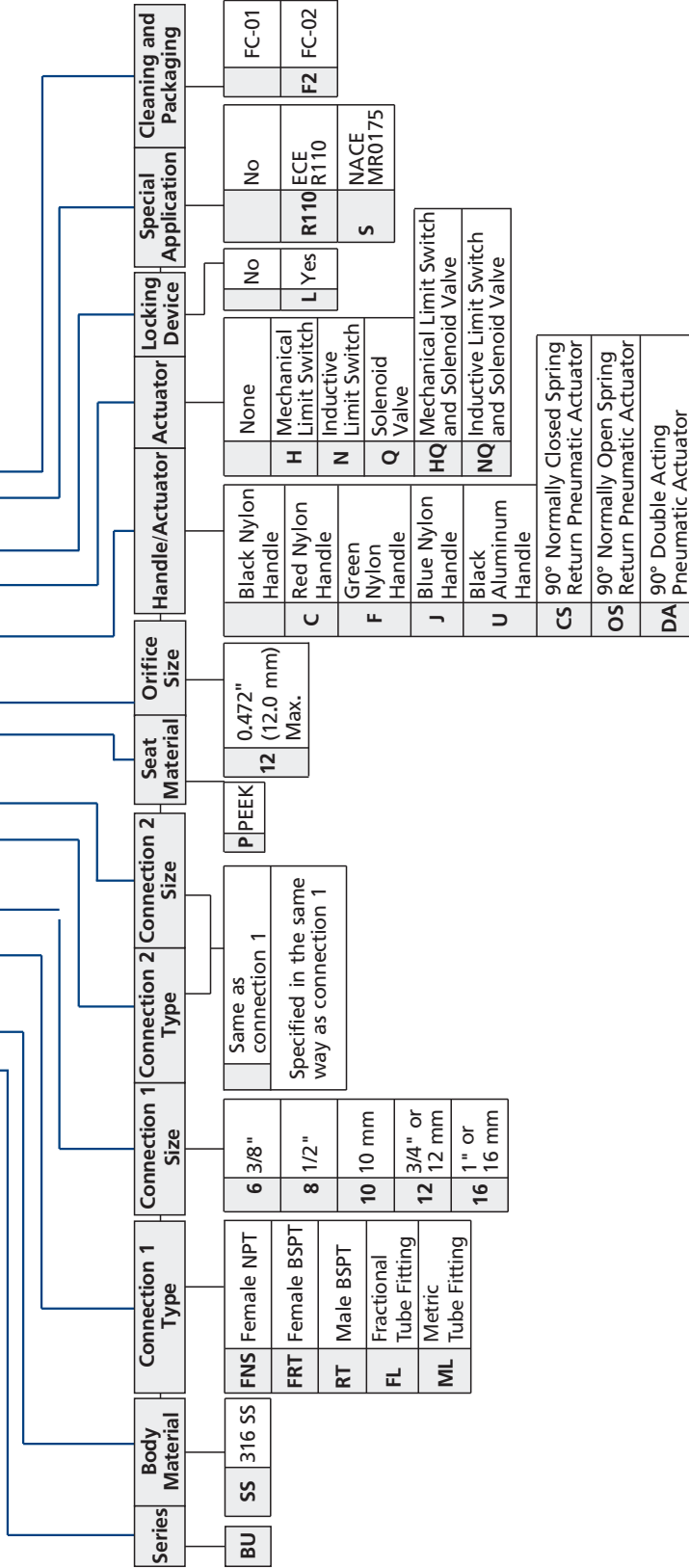

Note: "Ordering Number Description" is a reference to understand the combination rules of FITOK product part number. Not all combinations are available.

- Standard thread pitch for metric threads are as follows:
M10 and below: 1 mm
M12 to M24: 1.5 mm

Standard thread pitch is omitted in ordering number.

For special thread pitch, specify in the ordering number.

- For oxygen-enriched environment or hazardous media service, contact FITOK Group or our authorized distributors.

3. Cleaning and Packaging:

FC-01: Standard cleaning and packaging for general industrial procedures.

FC-02: Special cleaning and packaging for wetted system components to ensure compliance with product cleaning requirement of ASTM G93 Level C.

- For more details about ball valves with pneumatic actuators, refer to Automatic Control Ball Valves.

5. Certifications do not include attachments to the valve, such as actuators or a different handle mechanism.