

Quick Couplings

Quick Couplings



C-02

Quick Couplings

- HQP Series: 10,000 psig (690 bar)
- HQB Series: 10,000 psig (690 bar)
- HQS Series: 20,000 psig (1379 bar)
- HQC Series: 30,000 psig (2068 bar)



Fittings
Tubing
Quick Couplings
Line Filters
Valves
Sour Service Products
Subsea Valves
Tools and Installation Instructions
Technical Information
Part Number Crossover Charts

Contents

HQP Series	C-04
HQB Series	C-06
HQS Series	C-08
HQC Series	C-10
Ordering Number Description	C-16

Fittings

Tubing

Quick Couplings

Line Filters

Valves

Sour Service
Products

Subsea Valves

Tools and
Installation
InstructionsTechnical
InformationPart Number
Crossover Charts

HQP Series

Features

- ⦿ Working pressure: 10,000 psig (690 bar)
- ⦿ Fluorocarbon FKM O-ring for operation from 0°F to 400°F (-17.8°C to 204°C); other O-ring materials available
- ⦿ Stem and body material: high tensile 316 Stainless Steel
- ⦿ Push-and-pull type quick coupling without check valve, incapable of withstanding any pressure when disconnected
- ⦿ Flow coefficient (Cv) up to 8.2
- ⦿ Sturdy locking mechanism with large contact area to ensure reliable stem retainment
- ⦿ Slip sleeve lock design prevents accidental disconnection

Cautions

- ⦿ Do not disconnect or connect quick couplings when system is pressurized
- ⦿ Do not rotate quick couplings when connected
- ⦿ Take care to protect the nipple and coupler when disconnected

Standard Materials of Construction

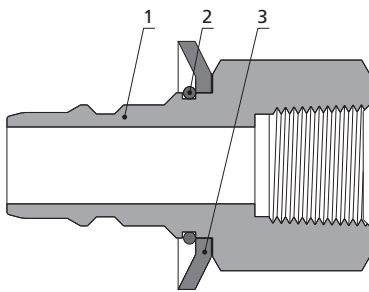

Nipple

Item	Component	Material Grade
1	<i>Stem</i>	316 SS
2	Wire Ring	Stainless Steel
3	Pull Piece	316 SS

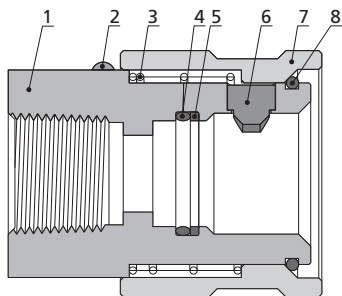

Coupler

Item	Component	Material Grade
1	<i>Body</i>	316 SS
2	Pin	Stainless Steel
3	Spring	300 Series SS
4	<i>O-ring</i>	Fluorocarbon FKM
5	Retaining Ring	PTFE
6	Locking Block	Stainless Steel
7	Slip Sleeve	316 SS
8	Wire Ring	Stainless Steel

Wetted component listed in italics.

Fittings
Tubing
Quick Couplings
Line Filters
Valves
Sour Service Products
Subsea Valves
Tools and Installation Instructions
Technical Information
Part Number Crossover Charts

Ordering Information and Dimensions

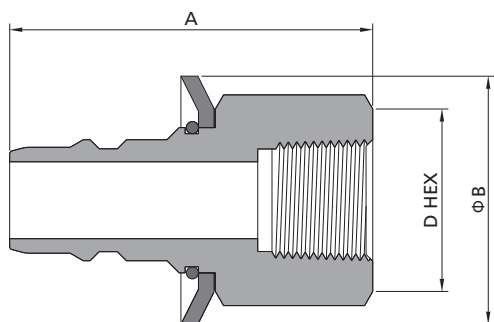

Nipple

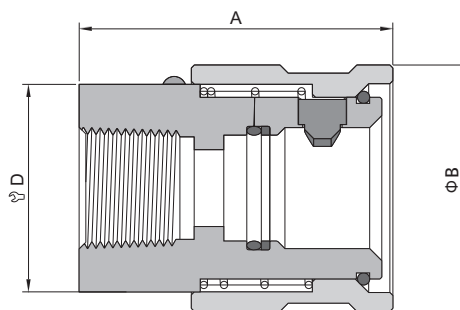

Coupler

Type	Ordering Number	Connection	Dimensions, in. (mm)			Working Pressure psig (bar)
			A	B	D	
Nipple	HQPSS-FNS6-NP	FNS6	2.17 (55.0)	1.59 (40.4)	1.19 (30.2)	10,000 (690)
	HQPSS-FNS8-NP	FNS8	2.36 (60.0)	1.59 (40.4)	1.19 (30.2)	
Coupler	HQPSS-FNS6-CP	FNS6	2.05 (52.0)	1.59 (40.4)	1.19 (30.2)	
	HQPSS-FNS8-CP	FNS8	2.05 (52.0)	1.59 (40.4)	1.19 (30.2)	

NOTE: All dimensions are shown for reference only and are subject to change. For dimensions not shown above, please contact FITOK Group or our authorized distributors.

Fittings
Tubing
Quick Couplings
Line Filters
Valves
Sour Service Products
Subsea Valves
Tools and Installation Instructions
Technical Information
Part Number Crossover Charts

HQB Series

Features

- ⦿ Working Pressure: 10,000 psig (690 bar)
- ⦿ Fluorocarbon FKM O-ring for operation from 0°F to 400°F (-17.8°C to 204°C); other O-ring materials available
- ⦿ S17400 Stainless Steel stem and high tensile 316 Stainless Steel body
- ⦿ Screw type quick coupling with check valve, capable of withstanding full pressure when disconnected
- ⦿ Flow coefficient (Cv) up to 0.53
- ⦿ Check valve with metal ball sealing, without guarantee of full gas impermeability

Cautions

- ⦿ Do not disconnect or connect quick couplings when system is pressurized
- ⦿ Finger tighten the threads to "face-to-face" station when connected
- ⦿ Take care to protect the nipple and coupler when disconnected

Standard Materials of Construction

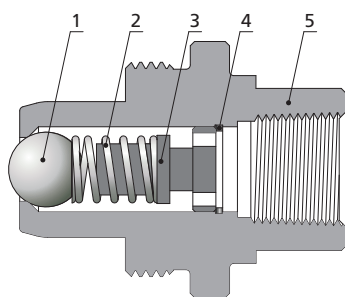

Nipple

Item	Component	Material Grade
1	<i>Ball</i>	<i>Stainless Steel</i>
2	<i>Spring</i>	<i>300 Series SS</i>
3	<i>Seat</i>	<i>316 SS</i>
4	<i>Retaining Ring</i>	<i>Stainless Steel</i>
5	<i>Stem</i>	<i>S17400 SS</i>

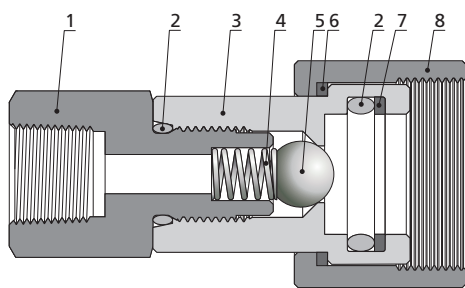

Coupler

Item	Component	Material Grade
1	<i>Body</i>	<i>316 SS</i>
2	<i>O-ring</i>	<i>Fluorocarbon FKM</i>
3	<i>Housing</i>	<i>S17400 SS</i>
4	<i>Spring</i>	<i>300 Series SS</i>
5	<i>Ball</i>	<i>Stainless Steel</i>
6	<i>Ring</i>	<i>C63000</i>
7	<i>Retaining Ring</i>	<i>PTFE</i>
8	<i>Nut</i>	<i>S17400 SS</i>
<i>Sealant adhesive</i>		<i>Anaerobic adhesive</i>

Wetted component listed in italics.

Fittings
 Tubing
 Quick Couplings
 Line Filters
 Valves
 Sour Service Products
 Subsea Valves
 Tools and Installation Instructions
 Technical Information
 Part Number Crossover Charts

Ordering Information and Dimensions

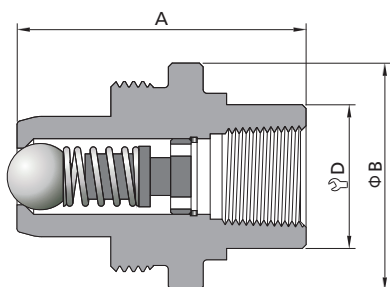

Nipple

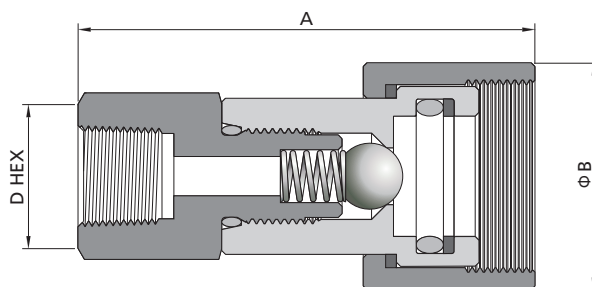

Coupler

Type	Ordering Number	Connection	Dimensions, in. (mm)			Working Pressure psig (bar)
			A	B	D	
Nipple	HQB4P-FNS4-NP	FNS4	1.54 (39.2)	1.18 (30.0)	0.75 (19.0)	10,000 (690)
	HQB4P-FNS6-NP	FNS6	1.54 (39.2)	1.18 (30.0)	0.94 (23.8)	
Coupler	HQB4P-FNS4-CP	FNS4	2.46 (62.4)	1.18 (30.0)	0.87 (22.2)	
	HQB4P-FNS6-CP	FNS6	2.46 (62.4)	1.18 (30.0)	0.94 (23.8)	

NOTE: All dimensions are shown for reference only and are subject to change. Other dimensions are available upon request.

Fittings
Tubing
Quick Couplings
Line Filters
Valves
Sour Service Products
Subsea Valves
Tools and Installation Instructions
Technical Information
Part Number Crossover Charts

HQS Series

Features

- ⦿ Working pressure up to 20,000 psig (1379 bar)
- ⦿ Fluorocarbon FKM O-ring for operation from 0°F to 400°F (-17.8°C to 204°C); other O-ring materials available
- ⦿ High tensile 316 Stainless Steel stem and S17400 Stainless Steel body
- ⦿ Screw type quick coupling without check valve, incapable of withstanding any pressure when disconnected
- ⦿ Flow coefficient (Cv) up to 33.4

Cautions

- ⦿ Do not disconnect or connect quick couplings when system is pressurized
- ⦿ Finger tighten the threads to "face-to-face" station when connected
- ⦿ Take care to protect the nipple and coupler when disconnected

Standard Materials of Construction

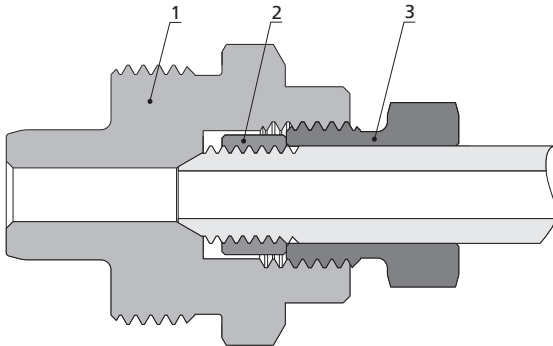

Nipple

Item	Component	Material Grade
1	Stem	316 SS
2	Collar	316 SS (For tubing connections)
3	Gland	316 SS (For tubing connections)

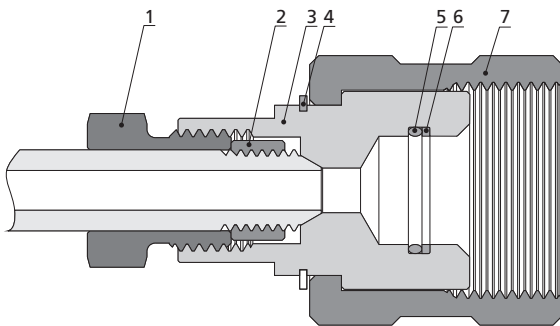

Coupler

Item	Component	Material Grade
1	Gland	316 SS (For tubing connections)
2	Collar	316 SS (For tubing connections)
3	Body	S17400 SS
4	Circlip	Stainless Steel
5	O-ring	Fluorocarbon FKM
6	Retaining Ring	PTFE
7	Nut	316 SS

Wetted component listed in italics

- Fittings
- Tubing
- Quick Couplings
- Line Filters
- Valves
- Sour Service Products
- Subsea Valves
- Tools and Installation Instructions
- Technical Information
- Part Number Crossover Charts

Ordering Information and Dimensions

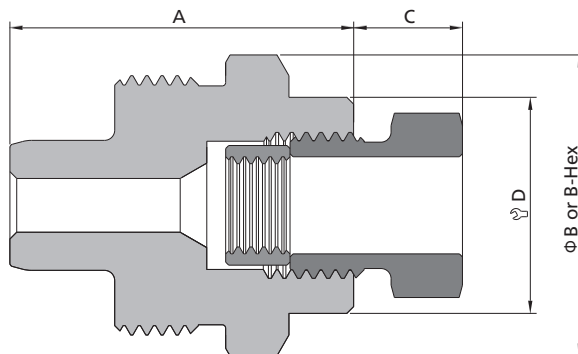

Nipple

Type	Ordering Number	Connection	Dimensions, in. (mm)				Working Pressure psig (bar)
			A	B	C	D	
Nipple	HQSSS-MF9-NP	MF9	2.40 (61.0)	1.74 (44.2)	0.55 (14.0)	1.25 (31.8)	20,000 (1379)
	HQSSS-FNS8-NP	FNS8	2.40 (61.0)	1.74 (44.2)	/	1.25 (31.8)	15,000 (1034)
	HQSSS-FNS12-NP	FNS12	2.48 (63.0)	2.00 (50.8)	/	/	10,000 (690)
	HQSSS-FNS16-NP	FNS16	2.60 (66.0)	2.25 (57.2)	/	/	10,000 (690)

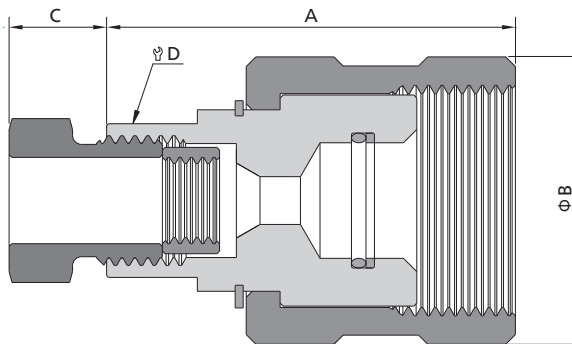

Coupler

Type	Ordering Number	Connection	Dimensions, in. (mm)				Working Pressure psig (bar)
			A	B	C	D	
Coupler	HQSSS-MF9-CP	MF9	2.61 (66.3)	1.91 (48.4)	0.55 (14.0)	1.00 (25.4)	20,000 (1379)
	HQSSS-FNS8-CP	FNS8	2.61 (66.3)	1.91 (48.4)	/	1.00 (25.4)	15,000 (1034)
	HQSSS-FNS12-CP	FNS12	3.03 (77.0)	2.38 (60.4)	/	1.38 (34.9)	10,000 (690)
	HQSSS-FNS16-CP	FNS16	3.24 (82.4)	2.57 (65.4)	/	1.63 (41.3)	10,000 (690)

NOTE: All dimensions are shown for reference only and are subject to change. Other dimensions are available upon request.

Fittings
Tubing
Quick Couplings
Line Filters
Valves
Sour Service Products
Subsea Valves
Tools and Installation Instructions
Technical Information
Part Number Crossover Charts

HQC Series

HQC Series Couplers

Features

- ⦿ Working pressure up to 30,000 psig (2068 bar)
- ⦿ Fluorocarbon FKM O-ring for operation from 0°F to 400°F (-17.8°C to 204°C); other O-ring materials available
- ⦿ Body material: S17400 Stainless Steel
- ⦿ Push-and-pull type coupler with check valve, capable of withstanding full pressure when disconnected
- ⦿ Flow coefficient (Cv) up to 0.66

Cautions

- ⦿ Do not disconnect or connect quick couplings when system is pressurized
- ⦿ Do not rotate quick couplings when connected
- ⦿ Take care to protect the nipple and coupler when disconnected

Standard Materials of Construction

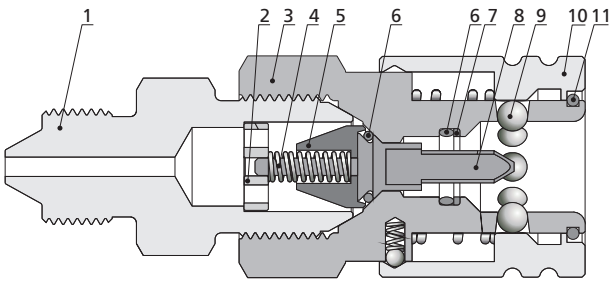

Item	Component	Material Grade
1	<i>Body</i>	<i>S17400 SS</i>
2	<i>Seat</i>	<i>316 SS</i>
3	<i>Housing</i>	<i>S17400 SS</i>
4	<i>Spring</i>	<i>300 Series SS</i>
5	<i>Valve Head</i>	<i>316 SS</i>
6	<i>O-ring</i>	<i>Fluorocarbon FKM</i>
7	Retaining Ring	PTFE
8	<i>Valve Stem</i>	<i>316 SS</i>
9	Ball	Stainless Steel
10	Sleeve	316 SS
11	Wire Ring	Stainless Steel

Wetted component listed in italics.

Ordering Information and Dimensions

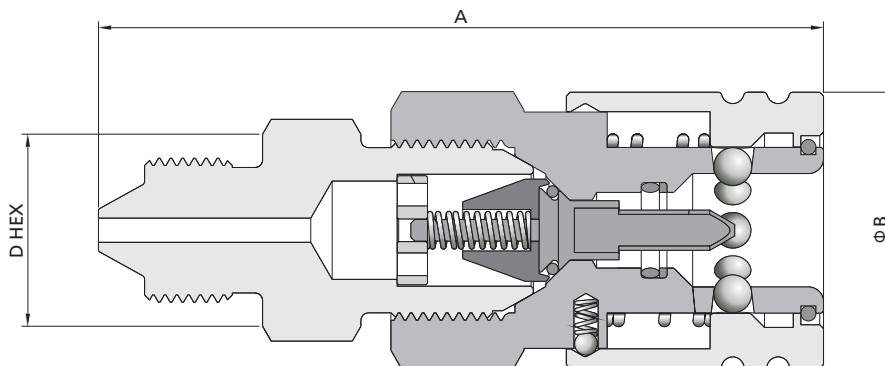

Fittings
Tubing
Quick Couplings
Line Filters
Valves
Sour Service Products
Subsea Valves
Tools and Installation Instructions
Technical Information
Part Number Crossover Charts

Type	Ordering Number	Connection	Dimensions, in. (mm)			Working Pressure psig (bar)
			A	B	D	
Coupler	HQC4P-NS4-CP	NS4	3.48 (88.5)	1.39 (35.4)	1.00 (25.4)	15,000 (1034)
	HQC4P-NS6-CP	NS6	3.48 (88.5)	1.39 (35.4)	1.00 (25.4)	15,000 (1034)
	HQC4P-NS8-CP	NS8	3.68 (93.5)	1.39 (35.4)	1.00 (25.4)	15,000 (1034)
	HQC4P-FNS4-CP	FNS4	3.17 (80.5)	1.39 (35.4)	1.00 (25.4)	15,000 (1034)
	HQC4P-FNS6-CP	FNS6	3.27 (83.0)	1.39 (35.4)	1.13 (28.6)	15,000 (1034)
	HQC4P-FNS8-CP	FNS8	3.56 (90.5)	1.39 (35.4)	1.38 (34.9)	15,000 (1034)
	HQC4P-JM4-CP	JM4	3.48 (88.5)	1.39 (35.4)	1.00 (25.4)	20,000 (1379)
	HQC4P-JM6-CP	JM6	3.48 (88.5)	1.39 (35.4)	1.00 (25.4)	20,000 (1379)
	HQC4P-JM8-CP	JM8	3.58 (91.0)	1.39 (35.4)	1.00 (25.4)	20,000 (1379)
	HQC4P-MM4-CP	MM4	3.62 (92.0)	1.39 (35.4)	1.00 (25.4)	20,000 (1379)
	HQC4P-MM6-CP	MM6	3.76 (95.5)	1.39 (35.4)	1.00 (25.4)	20,000 (1379)
	HQC4P-MM9-CP	MM9	3.95 (100.5)	1.39 (35.4)	1.00 (25.4)	20,000 (1379)
	HQC4P-HM4-CP	HM4	3.54 (90.0)	1.39 (35.4)	1.00 (25.4)	30,000 (2068)
	HQC4P-HM6-CP	HM6	3.80 (96.5)	1.39 (35.4)	1.00 (25.4)	30,000 (2068)
	HQC4P-HM9-CP	HM9	3.98 (101.0)	1.39 (35.4)	1.19 (30.2)	30,000 (2068)
	HQC4P-TM9-CP	TM9	3.43 (87.0)	1.39 (35.4)	1.00 (25.4)	30,000 (2068)
	HQC4P-TM12-CP	TM12	3.56 (90.5)	1.39 (35.4)	1.00 (25.4)	30,000 (2068)
	HQC4P-TM16-CP	TM16	3.56 (90.5)	1.39 (35.4)	1.00 (25.4)	30,000 (2068)

NOTE: All dimensions are shown for reference only and are subject to change. Other dimensions are available upon request.

Fittings

Tubing

Quick Couplings

Line Filters

Valves

Sour Service Products

Subsea Valves

Tools and Installation Instructions

Technical Information

Part Number Crossover Charts

HQC Series Nipples with Check Valve

Features

- ⦿ Working pressure up to 30,000 psig (2068 bar)
- ⦿ Fluorocarbon FKM O-ring for operation from 0°F to 400°F (-17.8°C to 204°C); other O-ring materials available
- ⦿ Stem material: S17400 Stainless Steel
- ⦿ Push-and-pull type nipple with check valve, capable of withstanding full pressure when disconnected
- ⦿ Flow coefficient (Cv) up to 0.66

Cautions

- ⦿ Do not disconnect or connect quick couplings when system is pressurized
- ⦿ Do not rotate quick couplings when connected
- ⦿ Take care to protect the nipple and coupler when disconnected

Standard Materials of Construction

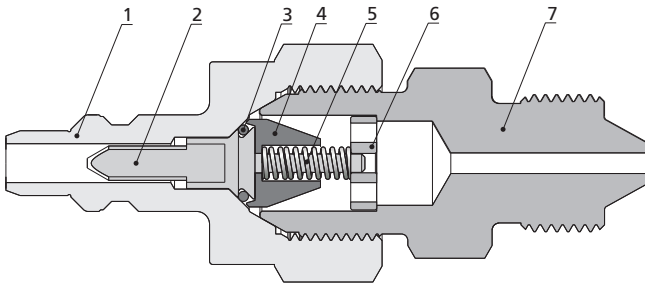

Item	Component	Material Grade
1	<i>Stem</i>	<i>S17400 SS</i>
2	<i>Valve Stem</i>	<i>316 SS</i>
3	<i>O-ring</i>	<i>Fluorocarbon FKM</i>
4	<i>Valve Head</i>	<i>316 SS</i>
5	<i>Spring</i>	<i>300 Series SS</i>
6	<i>Seat</i>	<i>316 SS</i>
7	<i>Body</i>	<i>S17400</i>

Wetted component listed in italics.

Ordering Information and Dimensions

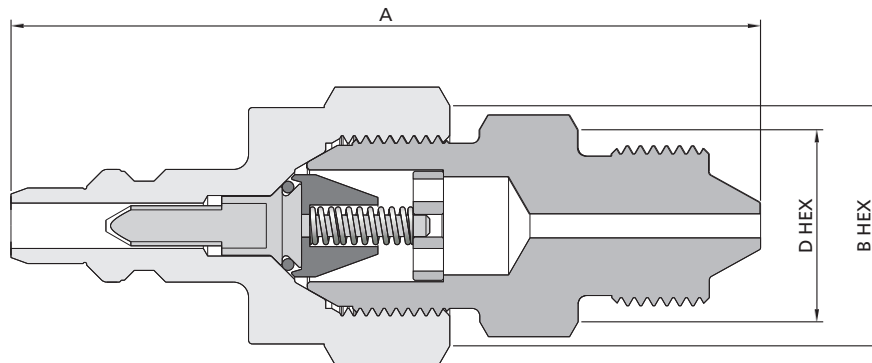

Type	Ordering Number	Connection	Dimensions, in. (mm)			Working Pressure psig (bar)
			A	B	D	
Nipple	HQC4P-NS4-NP	NS4	3.52 (89.5)	1.25 (31.8)	1.00 (25.4)	15,000 (1034)
	HQC4P-NS6-NP	NS6	3.52 (89.5)	1.25 (31.8)	1.00 (25.4)	15,000 (1034)
	HQC4P-NS8-NP	NS8	3.70 (94.0)	1.25 (31.8)	1.00 (25.4)	15,000 (1034)
	HQC4P-FNS4-NP	FNS4	3.19 (81.0)	1.25 (31.8)	1.00 (25.4)	15,000 (1034)
	HQC4P-FNS6-NP	FNS6	3.31 (84.0)	1.25 (31.8)	1.13 (28.6)	15,000 (1034)
	HQC4P-FNS8-NP	FNS8	3.58 (91.0)	1.25 (31.8)	1.38 (34.9)	15,000 (1034)
	HQC4P-JM4-NP	JM4	3.50 (89.0)	1.25 (31.8)	1.00 (25.4)	20,000 (1379)
	HQC4P-JM6-NP	JM6	3.50 (89.0)	1.25 (31.8)	1.00 (25.4)	20,000 (1379)
	HQC4P-JM8-NP	JM8	3.43 (92.0)	1.25 (31.8)	1.00 (25.4)	20,000 (1379)
	HQC4P-MM4-NP	MM4	3.64 (92.5)	1.25 (31.8)	1.00 (25.4)	20,000 (1379)
	HQC4P-MM6-NP	MM6	3.80 (96.5)	1.25 (31.8)	1.00 (25.4)	20,000 (1379)
	HQC4P-MM9-NP	MM9	3.98 (101.0)	1.25 (31.8)	1.00 (25.4)	20,000 (1379)
	HQC4P-HM4-NP	HM4	3.58 (91.0)	1.25 (31.8)	1.00 (25.4)	30,000 (2068)
	HQC4P-HM6-NP	HM6	3.84 (97.5)	1.25 (31.8)	1.00 (25.4)	30,000 (2068)
	HQC4P-HM9-NP	HM9	4.02 (102.0)	1.25 (31.8)	1.19 (30.2)	30,000 (2068)
	HQC4P-TM9-NP	TM9	3.46 (88.0)	1.25 (31.8)	1.00 (25.4)	30,000 (2068)
	HQC4P-TM12-NP	TM12	3.58 (91.0)	1.25 (31.8)	1.00 (25.4)	30,000 (2068)
	HQC4P-TM16-NP	TM16	3.60 (91.5)	1.25 (31.8)	1.00 (25.4)	30,000 (2068)

NOTE: All dimensions are shown for reference only and are subject to change. Other dimensions are available upon request.

Fittings

Tubing

Quick Couplings

Line Filters

Valves

Sour Service
Products

Subsea Valves

Tools and
Installation
InstructionsTechnical
InformationPart Number
Crossover Charts

HQC Series Nipples without Check Valve

Features

- ⦿ Working pressure up to 30,000 psig (2068 bar)
- ⦿ Stem material: S17400 Stainless Steel
- ⦿ Push-and-pull type nipple without check valve, incapable of withstanding any pressure when disconnected
- ⦿ Flow coefficient (Cv) up to 0.66

Cautions

- ⦿ Do not disconnect or connect quick couplings when system is pressurized
- ⦿ Do not rotate quick couplings when connected
- ⦿ Take care to protect the nipple and coupler when disconnected

Ordering Information and Dimensions

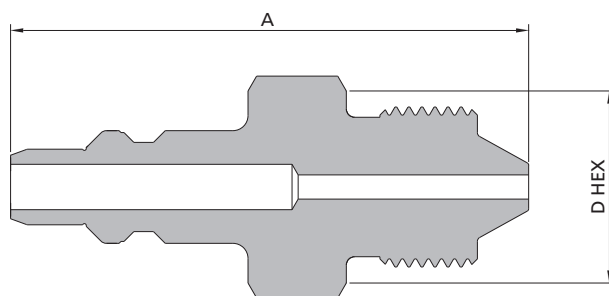

Fittings
Tubing
Quick Couplings
Line Filters
Valves
Sour Service Products
Subsea Valves
Tools and Installation Instructions
Technical Information
Part Number Crossover Charts

Type	Ordering Number	Connection	Dimensions, in. (mm)		Working Pressure psig (bar)
			A	D	
Nipple	HQC4P-NS4-NPO	NS4	2.25 (57.1)	1.00 (25.4)	15,000 (1034)
	HQC4P-NS6-NPO	NS6	2.25 (57.1)	1.00 (25.4)	15,000 (1034)
	HQC4P-NS8-NPO	NS8	2.44 (62.0)	1.00 (25.4)	15,000 (1034)
	HQC4P-FNS4-NPO	FNS4	2.05 (52.0)	1.00 (25.4)	15,000 (1034)
	HQC4P-FNS6-NPO	FNS6	2.09 (53.0)	1.13 (28.6)	15,000 (1034)
	HQC4P-FNS8-NPO	FNS8	2.36 (60.0)	1.38 (34.9)	15,000 (1034)
	HQC4P-JM4-NPO	JM4	2.24 (56.9)	1.00 (25.4)	20,000 (1379)
	HQC4P-JM6-NPO	JM6	2.24 (57.0)	1.00 (25.4)	20,000 (1379)
	HQC4P-JM8-NPO	JM8	2.35 (59.6)	1.00 (25.4)	20,000 (1379)
	HQC4P-MM4-NPO	MM4	2.37 (60.3)	1.00 (25.4)	20,000 (1379)
	HQC4P-MM6-NPO	MM6	2.52 (64.0)	1.00 (25.4)	20,000 (1379)
	HQC4P-MM9-NPO	MM9	2.69 (68.3)	1.00 (25.4)	20,000 (1379)
	HQC4P-HM4-NPO	HM4	2.31 (58.7)	1.00 (25.4)	30,000 (2068)
	HQC4P-HM6-NPO	HM6	2.56 (65.1)	1.00 (25.4)	30,000 (2068)
	HQC4P-HM9-NPO	HM9	2.81 (71.4)	1.19 (30.2)	30,000 (2068)
	HQC4P-TM9-NPO	TM9	2.19 (55.6)	1.00 (25.4)	30,000 (2068)
	HQC4P-TM12-NPO	TM12	2.32 (58.9)	1.00 (25.4)	30,000 (2068)
	HQC4P-TM16-NPO	TM16	2.33 (59.2)	1.00 (25.4)	30,000 (2068)

NOTE: All dimensions are for reference only and are subject to change. For dimensions not shown above, please contact FITOK Group or our authorized distributors.

Fittings

Tubing

Quick Couplings

Line Filters

Valves

Sour Service Products

Subsea Valves

Tools and Installation Instructions

Technical Information

Part Number Crossover Charts

Ordering Number Description

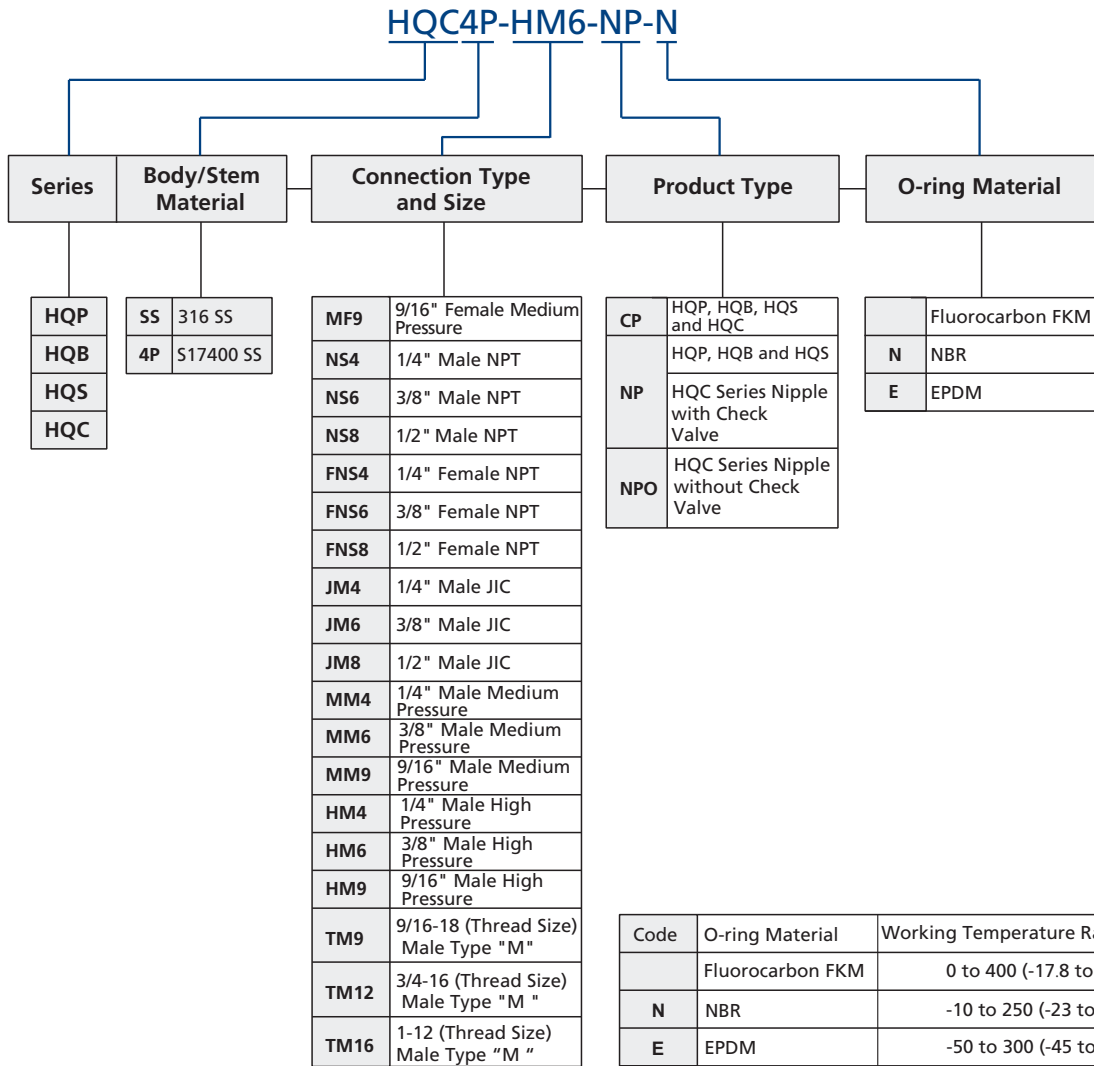

- NOTES: 1. For more details regarding Medium/High Pressure connections, please see **Connection Information** on I-02.
 2. "Ordering Number Description" is a reference to understand the combination rules of FITOK Product Part Number. Not all combinations are available.