

Sample Cylinders and Accessories



Vessels
Sample Cylinders

Sample Cylinders

Application

- ⦿ Hydrocarbon sampling for refineries
- ⦿ Gas sampling for chromatography experiments
- ⦿ Condensate sampling for fossil fuel and nuclear power plants
- ⦿ As surge accumulators or reaction vessels
- ⦿ As snubbers in reactor feed lines



Features

- ⦿ Capacities from 40 cm³ to 3785 cm³ (1 gal)
- ⦿ Spun cylinder body machined from seamless tubing to provide consistent wall thickness, size and capacity
- ⦿ Cold-formed female NPT thread to provide high strength
- ⦿ 1/8", 1/4" and 1/2" female NPT connections
- ⦿ Full-penetration gas tungsten arc-weld construction to ensure no leak for sampling (single-ended cylinder only)
- ⦿ DOT and non-DOT cylinders available
- ⦿ Accessories, such as valves, relief devices, outage tubes, carrying handles, caps and plugs available

Design

FITOK sample cylinders are designed and manufactured in compliance with 49 CFR, the stringent regulation of U.S. Department of Transportation, to provide high reliability and long service life.

Spun cylinders are made of seamless tubing to increase the wall thickness of neck transitions and thread areas which provides high strength to reduce the leak risks.

The cylinders are internal sandblasted to ensure smooth surface and minimized remaining particles for easy cleaning.

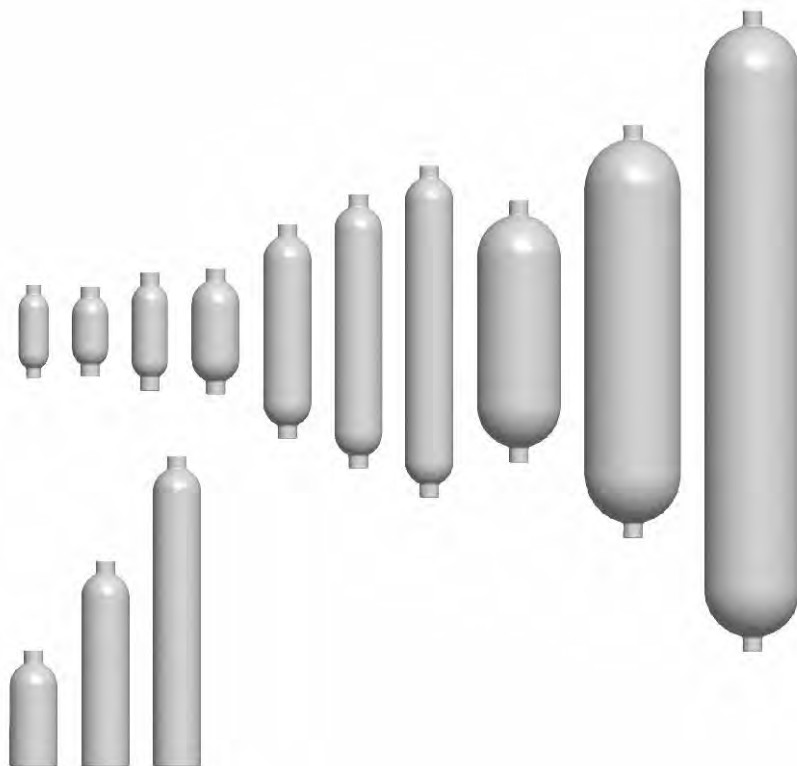

Materials

FITOK DOT cylinders are available in 304L SS and 316L SS. FITOK non-DOT cylinders are available in 304L SS, 316 L SS and Alloy 400. For cylinders of other materials, please contact FITOK Group or our authorized distributors.

Pressure - Temperature

Material	316L SS	316L SS, 304L SS	304L SS	Alloy 400	316 SS	304L SS
DOT Specification	DOT-3A 5000 TC-3ASM 344	DOT-3E 1800 TC-3EM 124	DOT-3A 1800 TC-3ASM 124	—	—	—
Temperature, °F (°C)	Working pressure, psig (bar)					
-65 (-53) to 100 (37)	5000 (344)	1800 (124)	1800 (124)	1800 (124)	1000 (69.0)	500 (34.4)
200 (93)	3960 (272)	1360 (93.7)	1360 (93.7)	1580 (108)	840 (57.8)	500 (34.4)
300 (148)	3570 (245)	1230 (84.7)	1230 (84.7)	1490 (102)	760 (52.3)	500 (34.4)
400 (204)	3290 (226)	1130 (77.8)	1130 (77.8)	1430 (98.5)	700 (48.2)	500 (34.4)
500 (260)	3060 (210)	1050 (72.3)	1050 (72.3)	1420 (97.8)	650 (44.7)	500 (34.4)
600 (315)	2920 (201)	1000 (69.0)	1000 (69.0)	1420 (97.8)	620 (42.7)	500 (34.4)
650 (343)	2870 (197)	980 (67.5)	980 (67.5)	1420 (97.8)	610 (42.0)	500 (34.4)
700 (371)	2810 (193)	970 (66.8)	970 (66.8)	1420 (97.8)	590 (40.6)	500 (34.4)
750 (398)	2750 (189)	950 (65.4)	950 (65.4)	1410 (97.1)	580 (39.9)	500 (34.4)
800 (426)	2700 (186)	930 (64.0)	930 (64.0)	—	570 (39.2)	500 (34.4)
850 (454)	2640 (181)	—	—	—	560 (38.5)	—

Notes:

1. Working temperature is limited to 300°F (148°C) maximum for cylinders with PTFE internal coating.
2. Working pressure and temperature may be restricted by individual local government regulations.

Testing

Single-ended Cylinders

All single-ended cylinders are hydrostatically tested at 1000 psig (69 bar).

Double-ended Cylinders

All double-ended cylinders are hydrostatically tested to at least 5/3 times the working pressure.

DOT-3A 1800 cylinders are hydrostatically tested at 3000 psig (206 bar) minimum .

DOT-3E 1800 cylinders are hydrostatically tested at 3050 psig (210 bar).

DOT-3A 5000 cylinders are hydrostatically tested at 8500 psig (586 bar) minimum.

Transportable Pressure Equipment Directive (TPED)

The Transportable Pressure Equipment Directive (TPED) provides requirements for the design, manufacturing, and testing of transportable pressure vessels and accessories, including sample cylinders and rupture discs. The directive aims to provide a uniform level of product safety throughout the European Union countries.

For information about FITOK TPED-compliant products, please refer to FITOK Catalog *Sample Cylinders Compliant with the Transportable Pressure Equipment Directive (TPED)*.

Technical Data

Dimensions are for reference only and are subject to change.

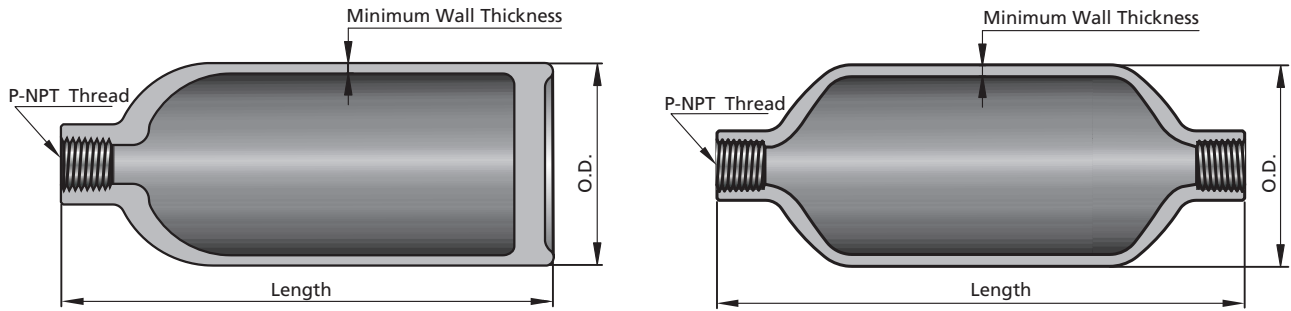

Material Grade/Cylinder Specification	Pressure Rating psig (bar)	Cylinder Volume (cm ³ ±10%)	P in.	Dimensions, in. (mm)			Weight lb (kg)
				O.D.	Length	Minimum Wall Thickness	
Single-ended							
304L SS/	500 (34.4)	150	1/4	2.00 (50.8)	4.88 (124)	0.093 (2.4)	1.10 (0.50)
		300			8.62 (219)		1.80 (0.82)
		500			13.6 (345)		2.70 (1.2)
Double-ended							
304L SS/ DOT-3E 1800	1800 (124)	40	1/8	1.25 (31.8)	3.88 (98.6)	0.070 (1.8)	0.31 (0.14)
		50	1/4	1.5 (38.1)	3.75 (95.2)		0.38 (0.17)
		75			4.94 (125)		0.62 (0.28)
		150 ^①	1/4	2.00 (50.8)	5.25 (133)	0.093 (2.4)	0.94 (0.43)
		290			8.86 (225)		1.79 (0.81)
		300 ^①			8.94 (227)		1.80 (0.83)
		400			11.4 (290)		2.10 (0.95)
		500 ^①			13.8 (351)		2.61 (1.20)
304L SS/ DOT-3A 1800	1800 (124)	1000 ^①	1/4 or 1/2	3.50 (88.9)	10.9 (277)	0.180 (4.6)	6.50 (2.90)
		2250 ^①	1/4 or 1/2	4.00 (102)	17.2 (437)	0.206 (5.2)	14.00 (6.40)
		3785 ^① (1 gal)			26.7 (678)		21.00 (9.50)
316L SS/ DOT-3E 1800	1800 (124)	150 ^①	1/4	2.00 (50.8)	5.25 (133)	0.093 (2.4)	0.94 (0.43)
		290			8.86 (225)		1.79 (0.81)
		300 ^①			8.94 (227)		1.80 (0.83)
		500 ^①			13.8 (351)		2.60 (1.20)
316L SS/ DOT-3A 5000	5000 (344)	150 ^①	1/4	1.90 (48.2)	8.00 (203)	0.240 (6.1)	3.00 (1.40)
		300 ^①			14.5 (368)		5.60 (2.50)
		500 ^①			23.5 (597)		9.10 (4.10)
Alloy 400	1800 (124)	150	1/4	2.00 (50.8)	5.25 (133)	0.093 (2.4)	0.94 (0.43)
		300			8.94 (227)		1.80 (0.82)
		500			13.8 (351)		2.90 (1.30)

^① DOT cylinders are available.

TC certified sample cylinders are also available upon request. For more information, please contact FITOK Group or our authorized distributors.

Options for Internal Cylinder Surface Treatments

PTFE Coating

The internal cylinder surface can be coated with PTFE to provide a nonstick surface for easy cleaning.

Electropolishing

Electropolishing can provide a clean internal surface with a high degree of passivation.

Cleaning and Packaging

All FITOK sample cylinders and cylinder valves are cleaned and packaged in accordance with FITOK *FC-01 Standard Cleaning and Packaging*.

FITOK *FC-02 Special Cleaning and Packaging* in compliance with the requirements of ASTM G93 Level C is optional.

Special Application Sample Cylinder

SilcoNert[®] 2000 (Sulfinert[®]) coated sample cylinders available, SilcoNert[®] 2000 (Sulfinert[®]) coating to provide stable storage of sulfur and mercury compounds at ppb levels in petroleum samples for a long time.

SilcoNert[®] 2000 (Sulfinert[®]) coating not flaking off and more durable than Teflon coating.

To order SilcoNert[®] 2000 (Sulfinert[®]) coated products, please add -SI as a suffix to the standard ordering number.

Example: 6L-SC18-DN4-H2-500-SI

Overpressure Protection

Cylinders for compressed air must be equipped with pressure relief devices in accordance with US DOT regulations and CGA Pamphlet S-1.1. The CGA Pamphlet lists devices that can be used with specific gases. It also contains information on other types of pressure relief devices.

- ▲ Be sure to use the correct pressure relief device for the gas being used.
- ▲ Proper filling of the cylinder according to DOT specifications or other local regulations, is critical in preventing overpressurization.

Rupture Disc Kits

Rupture disc kits protect sample cylinder from overpressurization by venting the gas to atmosphere.

The rupture disc kits are used to be installed in valves or rupture disc tees and sealed by O-rings.

The rupture disc kits can be easily replaced without removing valves or tees from cylinders.

Materials of Construction

Component	Material Grade/ASTM Specification
Body, inlet ring	316 SS/A479
Rupture disc	Alloy 600/B168
O-ring	Fluorocarbon FKM



Ordering Information

Nominal Burst Pressure at 70°F (20°C)	Ordering Number
2850 psig ± 150 psig 196 bar ± 10.3 bar	SS-RDD-7BS-2850
1900 psig ± 100 psig 130 bar ± 6.8 bar	SS-RDD-7BS-1900

Note: The rupture disc kits should be used with FITOK Rupture Disc Tees.

Rupture Disc Tees

These compact assemblies are designed for using with FITOK valves. Tees are made of 316 SS. Each tee is supplied with a rupture disc kit.

Ordering Information and Dimensions

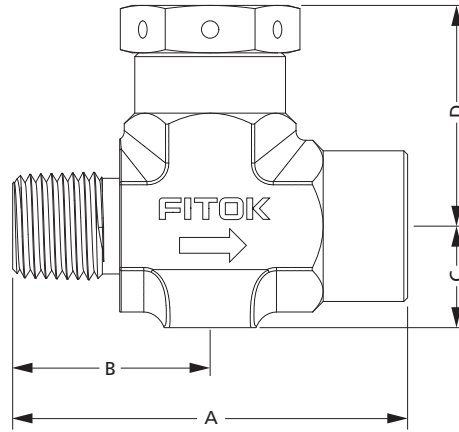

End Connections		Ordering Number	Dimensions, in. (mm)			
Inlet	Outlet		A	B	C	D
With 2850 psig (196 bar) Rupture Disc						
1/4 in. Male NPT	1/4 in. Female NPT	SS-TM4-F4-RD28	2.06 (52.4)	1.03 (26.2)	0.53 (13.5)	1.16 (29.4)
1/2 in. Male NPT		SS-TM8-F4-RD28	2.63 (66.7)	1.50 (38.1)	0.75 (19)	1.42 (36)
With 1900 psig (130 bar) Rupture Disc						
1/4 in. Male NPT	1/4 in. Female NPT	SS-TM4-F4-RD19	2.06 (52.4)	1.03 (26.2)	0.53 (13.5)	1.16 (29.4)
1/2 in. Male NPT		SS-TM8-F4-RD19	2.63 (66.7)	1.50 (38.1)	0.75 (19)	1.42 (36)

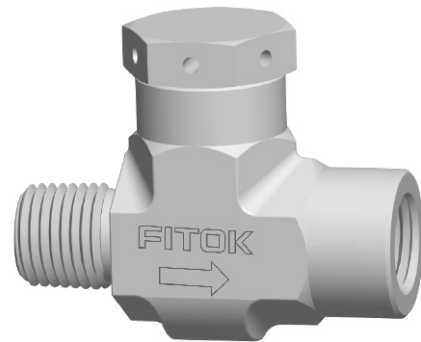

Nonrotating-stem Needle Valves with Rupture Disc Kits

Ordering Information and Dimensions

End Connections		Flow Pattern	Valve Ordering Number	Orifice in. (mm)
Inlet	Outlet			
With 2850 psig (196 bar) Rupture Disc				
1/4 in. Male NPT	1/4 in. Female NPT	Straight	NDSS-NS4-FNS4-7-SAFE2	0.16 (4.0)
			NDSS-NS4-FNS4-7-A-SAFE2	
1/2 in. Male NPT	1/4 in. Female NPT	Angle	NDSS-NS8-FNS4-8-A-SAFE2	0.22 (5.6)
1/2 in. Male NPT			NDSS-NS8-FNS4-8-A-SAFE2	0.22 (5.6)
With 1900 psig (130 bar) Rupture Disc				
1/4 in. Male NPT	1/4 in. Female NPT	Straight	NDSS-NS4-FNS4-7-SAFE1	0.16 (4.0)
			NDSS-NS4-FNS4-7-A-SAFE1	
1/2 in. Male NPT	1/4 in. Female NPT	Angle	NDSS-NS8-FNS4-8-A-SAFE1	0.22 (5.6)
1/2 in. Male NPT			NDSS-NS8-FNS4-8-A-SAFE1	0.22 (5.6)

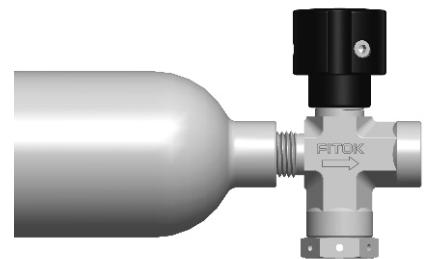

1. Dimensions are for reference only and are subject to change.
2. Other FITOK valves are available for using with sample cylinders. Please contact FITOK Group or our authorized distributors for details.

Spring Relief Devices

Introduction

- Spring relief devices can be used with FITOK sample cylinders as a safety device.
- When the system pressure reaches the set pressure, the device will open automatically to release the excess pressure in the system. After stabilizing the system pressure, the device will close automatically.



Working Temperature

-20°F~250°F (-29°C~121°C)

Materials of Construction

Item	Component	Material Grade/ASTM Specification
1	Body	316 SS/A182
2	Gasket	PCTFE/D1430
3	Seat	316 SS/A479
4	Stem	316 SS/A479+Fluorocarbon FKM
5	Spring	304 SS/A313
6	Bonnet	316 SS/A479

- Lubricant: Silicone-based.
- For other materials, please contact FITOK Group or our authorized distributors.

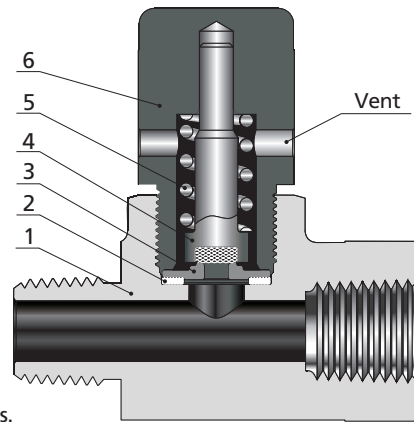

Dimensions and Ordering Information

All dimensions are for reference only and are subject to change.

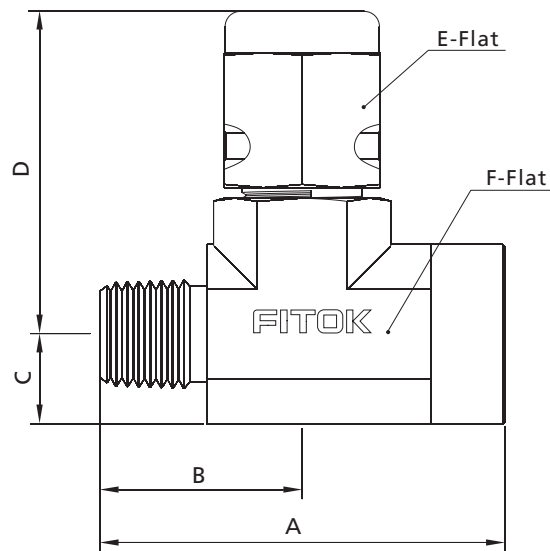

Basic Ordering Number	Connection Type and Size		Dimensions, in. (mm)						Set Pressure, psig (bar)
	Inlet	Outlet	A	B	C	D	E	F	
RTSS-NS4-FNS4-4	1 / 4 Male NPT	1 / 4 Female NPT	2.11 (53.6)	1.05 (26.8)	0.46 (11.7)	1.68 (42.7)	0.81 (20.6)	0.81 (20.6)	350 ~ 400 (24~27)
RTSS-NS4-FNS4-6									540 ~ 600 (37~41)
RTSS-NS4-FNS4-8									700 ~ 800 (48~55)
RTSS-NS6-FNS4-4	3 / 8 Male NPT								350 ~ 400 (24~27)
RTSS-NS6-FNS4-6									540 ~ 600 (37~41)
RTSS-NS6-FNS4-8									700 ~ 800 (48~55)

For other set pressures, please contact FITOK Group or our authorized distributors.

Sample Cylinder Accessories

Carrying Handle

The carrying handle provides convenience for transportation of sample cylinders. The handle is made of 304 SS and is available for 290 cm³ cylinders or larger cylinders.

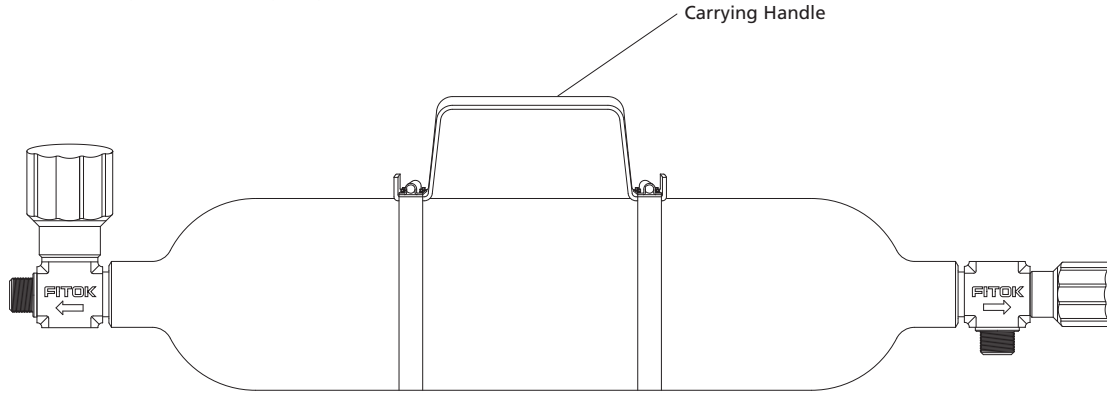

Ordering Information

Cylinder OD in. (mm)	Cylinder Volume cm ³	Ordering Number
1.9 (48.2)	290~500	HD-CY2-H2
2.0 (50.8)		
3.5 (88.9)	1000	HD-CY3-H2
4.0 (102)	2250/3785	HD-CY4-H4

Caps and Plugs

Caps and plugs are used for cylinder valves to protect the connections (tube fitting or NPT thread) from damages during cylinder transportation. For details, please contact FITOK Group or our authorized distributors.

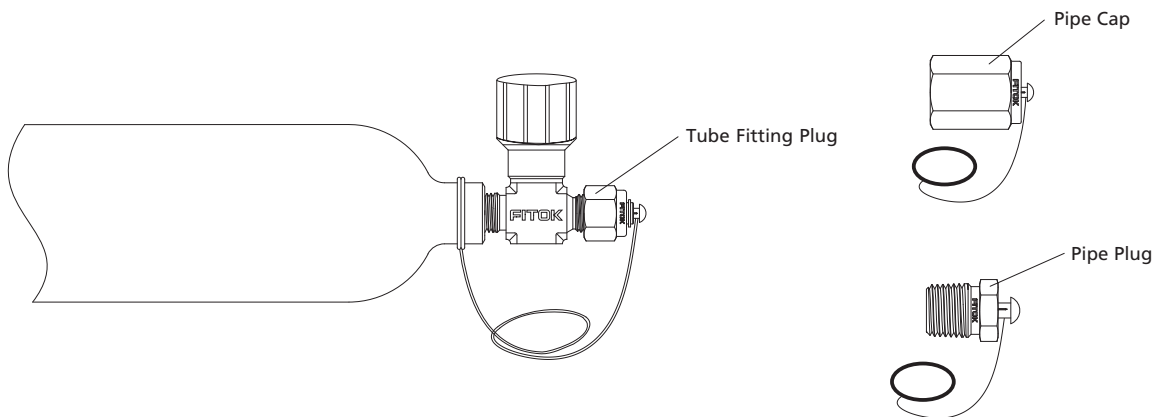

End Caps

In order to enable users to transport pressurized samples in safety, end caps are offered by FITOK to protect valves from damages. Each end cap is screwed onto a neck ring that has been cold forged to the cylinder neck. End caps are made of carbon steel and are only available for 2250 cm³ and 3785 cm³ (1 gal) cylinders . FITOK angle pattern valves can be used for cylinders with end caps.

Note: Double-ended cylinders with end caps on both ends are standard configurations.

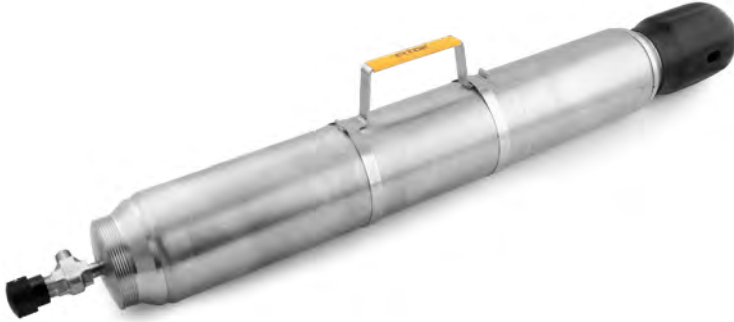

Outage Tubes

Features

- ◎ 316 SS and Alloy 400 available
- ◎ 1/4" and 1/2" NPT connections available

Construction

Outage tube is welded to the male thread end of an adapter. Screw the adapter with outage tube into the female thread end of a sample cylinder.

Purpose

The outage tube provides a vapor space of desired volume in a cylinder with liquefied gas. Therefore, liquids can expand when the temperature increases. A small temperature increase can make the liquids expanded and the pressure increased dramatically if there is not enough vapor space.

Note: For safe filling limits of your application, please refer to local regulations or other guidelines.

Usage

Outage tube is used to keep a certain vapor space in a cylinder.

The space is determined by the length of outage tube.

Outage is the vapor space in the cylinder expressed as a percentage of the total volume of the cylinder.

$$\% \text{ outage} = (\text{vapor space} / \text{total volume}) \times 100$$

To obtain an exact outage, each outage tube and cylinder assembly should be calibrated by a suitable method.

Outage Tube Length

The outage tube length (L) is measured from the end of the pipe fitting to the end of the tubing. The table below shows approximate outage tube length for standard sample cylinders.

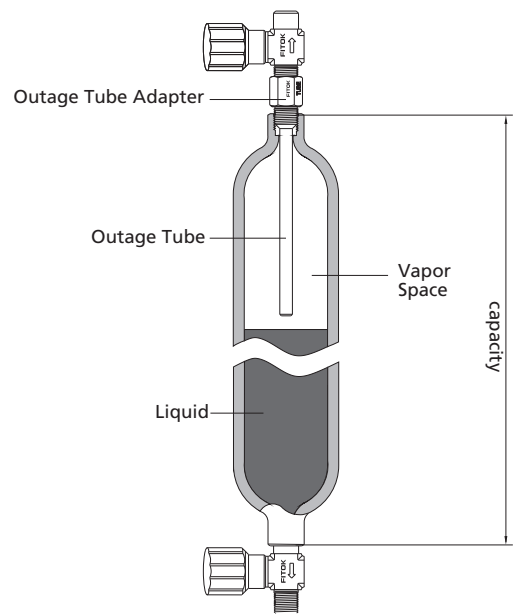

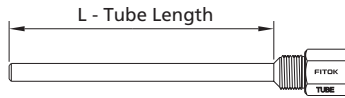

Tube of desired length is available upon request.

Tube O.D.	Cylinder Volume (cm ³ ±10%)	Code	Minimum Outage, %						
			10	20	30	40	50		
			Tube Length, in.						
1/4"	40	Applicable to double-ended cylinders rated to 1800 psig	4087	0.87	1.11	1.35	1.59	1.84	
	50		5085	0.85	1.07	1.28	1.50	1.71	
	75		5102	1.02	1.34	1.66	1.98	2.31	
	150		5112	1.12	1.45	1.79	2.13	2.46	
	300		5165	1.65	2.32	2.99	3.67	4.34	
5/16"	400		5200	2.00	2.90	3.79	4.69	5.59	
	500		5226	2.26	3.38	4.50	5.62	6.74	
	1000		5231	2.31	3.06	3.81	4.56	5.31	
	2250		5717	3.30	4.59	5.88	7.17	8.46	
	3785 (1 gal)		51114	4.62	6.79	8.96	11.14	13.31	
1/2"	1000		8221	2.21	2.96	3.71	4.46	5.21	
	2250		8846	3.30	4.59	5.88	7.17	8.46	
	3785 (1 gal)		8452	4.52	6.69	8.86	11.04	13.21	
5/16"	150		Applicable to single-ended cylinders rated to 500 psig	5109	1.09	1.43	1.77	2.12	2.46
	300			5159	1.59	2.27	2.96	3.65	4.34
	500	5560		2.16	3.30	4.45	5.60	6.74	
	150	Applicable to double-ended cylinders rated to 5000 psig	5162	1.62	2.17	2.71	3.26	3.81	
	300		5274	2.74	3.84	4.93	6.03	7.12	
	500		5439	4.39	6.21	8.04	9.86	11.68	

For the use of sample cylinder and outage tube, please refer to ASTM D1265, Standard Practice for Sampling Liquefied Petroleum (LP) Gases, Manual Method.

Ordering Number Description

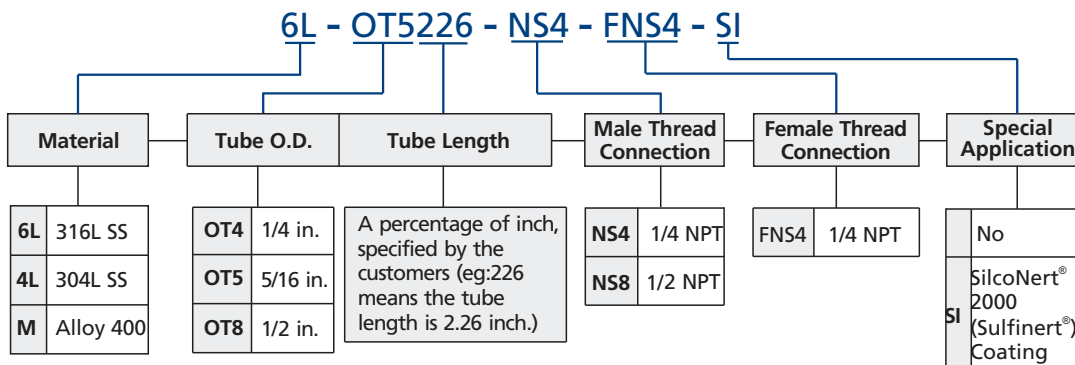

Note: "Ordering Number Description" is a reference to understand the combination rules of FITOK product part number. Not all combinations are available.

Ordering Number Description

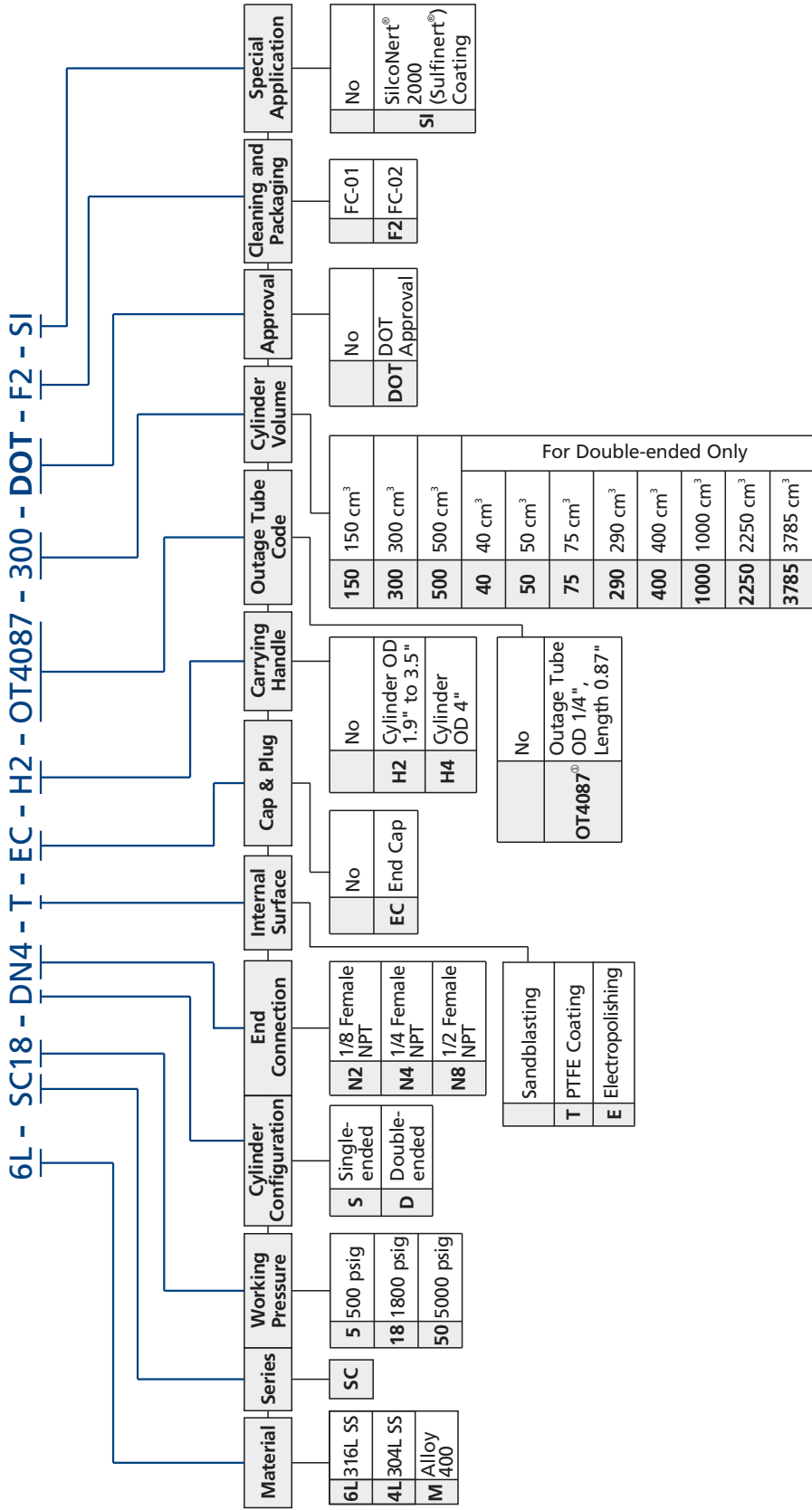

① For other outage tube codes, please refer to Page E-18 for details; the ordering number of sample cylinder with outage tube suffixed with -SI means the outage tube is also SilcoNert[®] 2000 (Sulfinert[®]) coated. Note: "Ordering Number Description" is a reference to understand the combination rules of FITOK product part number. Not all combinations are available.

Miniature Sample Cylinders

Features

- Maximum working pressure: 1000 psig (69.0 bar)
- Capacities: 10, 25 and 50 cm³
- Single-ended and double-ended configurations available
- Smooth internal neck transition for easy cleaning
- Stainless steel construction to ensure high corrosion resistance
- Full-penetration butt weld constructions

Dimensions

Dimensions, in inches (millimeters), are for reference only and are subject to change.

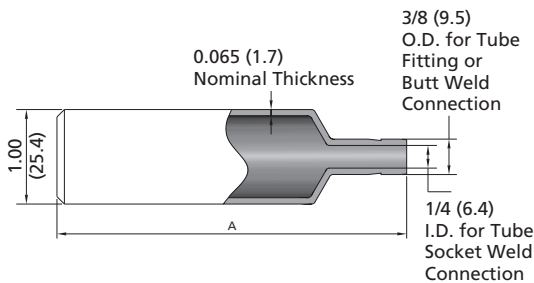

Cylinder Configuration	Cylinder Volume cm ³	Volume Tolerance	Working Pressure psig (bar)	A in. (mm)	Average Weight oz (g)
Single-ended	10	±10%	1000 (69.0)	2.19 (55.6)	2.2 (62)
	25	±5%		3.69 (93.7)	3.2 (91)
	50			6.25 (159)	5.6 (159)
Double-ended	10	±10%		2.75 (69.8)	1.9 (54)
	25	±5%		4.25 (108)	3.3 (94)
	50			6.81 (173)	5.1 (145)

Testing and Cleaning

Each miniature cylinder is pressure tested at 1667 psig (115 bar) with Nitrogen. Special Cleaning and Packaging in compliance with ASTM G93 Level C is optional.

Special Application Sample Cylinder

SilcoNert[®] 2000 (Sulfinert[®]) coated sample cylinders available, SilcoNert[®] 2000 (Sulfinert[®]) coating to provide stable storage of sulfur and mercury compounds at ppb levels in petroleum samples for a long time.

SilcoNert[®] 2000 (Sulfinert[®]) coating not flaking off and more durable than Teflon coating.

To order SilcoNert[®] 2000 (Sulfinert[®]) coated products, please add -SI as a suffix to the standard ordering number.

Example: 6L-SC18-DN4-H2-500-SI

Cautions

- No impingement during the usage of the cylinders.
- Don't expose the cylinders in the sun or bake next to the heat source.
- Sample cylinders are strictly prohibited roasting by fire when the cylinders are frozen.
- When using the sample cylinders, the working pressure should not exceed its maximum allowable working pressure.

Ordering Number Description

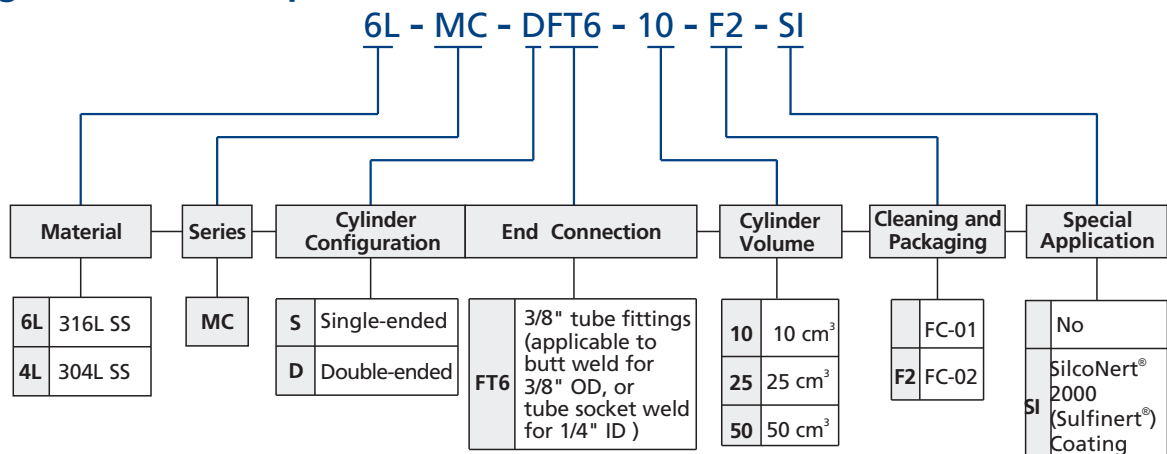

info@fitokgroup.com
www.fitokgroup.com

FK-IC-GC-02-EN-201117