

B Series

BLB1 - On-off Type with In-line Ball Valve

Features

- ⦿ Sampling from low pressure devices or process lines: 0-145 psig (0-10 bar)
- ⦿ In-line sampling
- ⦿ Fire safe and antistatic ball valve

Basic Configuration

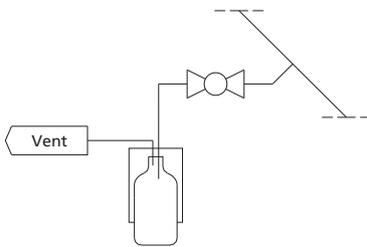
Wetted Material	316 SS	
Sleeve Assembly	250 ml sleeve with bottle retaining clip	
Needle Assembly	Process/vent needle ID: 1.4 mm (0.06")	
Sampling Valve	In-line ball valve: PTFE seat, fire safe and antistatic Max. working pressure: 276 psig @ 70°F (19 bar @ 20°C) Temperature range: -18°F to 298°F (-28°C to 148°C)	
Connections	Process: NPS 1/2, ANSI B16.5 Class 150 RF flange	
	Vent: 1/4" tube fitting	
Others	Spring return handle	

Note: Products of other specifications are available upon request.

Typical Installation Mode

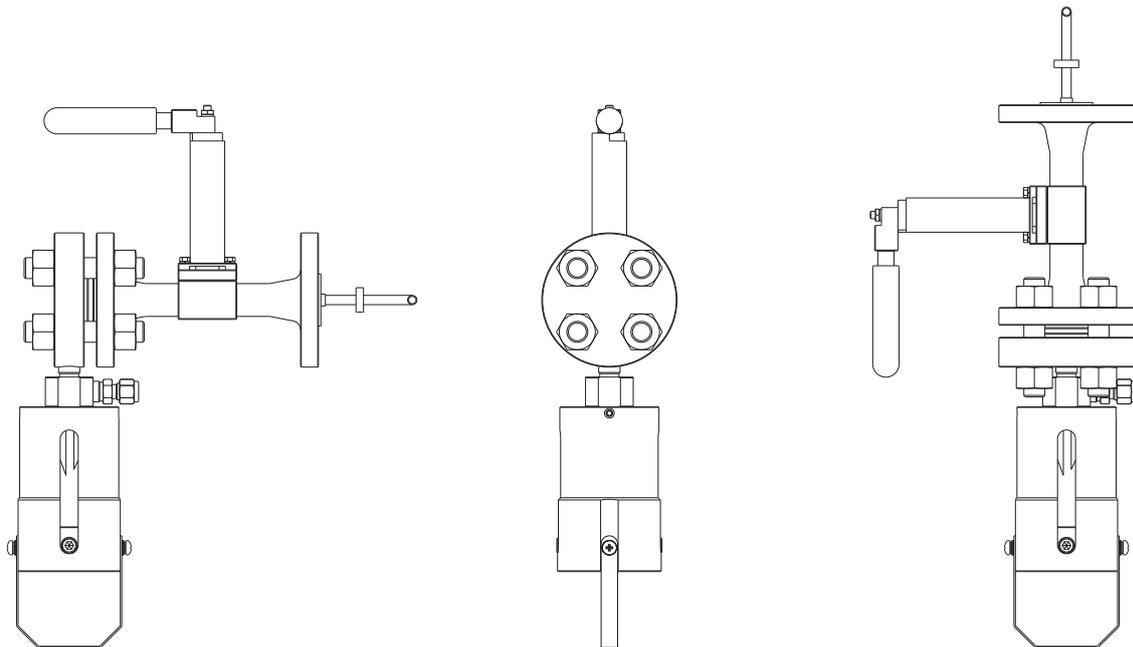

Operation

1 - Preparation

Place a new septum on the sample bottle. Insert the bottle with cap and septum into the sleeve until the septum is pierced by the needles. Swing down the bottle retaining clip.

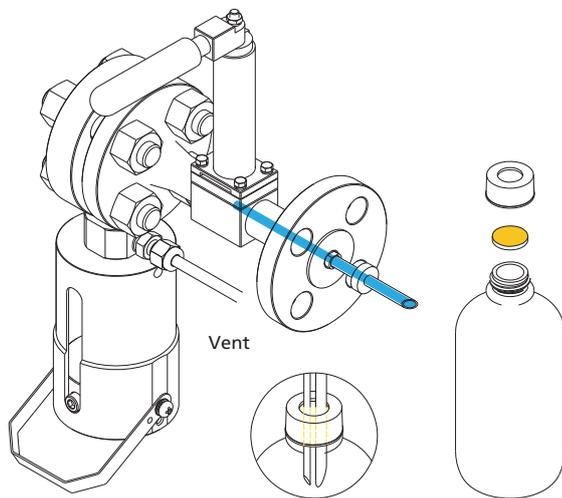

2 - Sampling

Open the in-line ball valve, allowing the sample to flow into the bottle. When the required amount has been taken, release the handle to close the valve automatically.

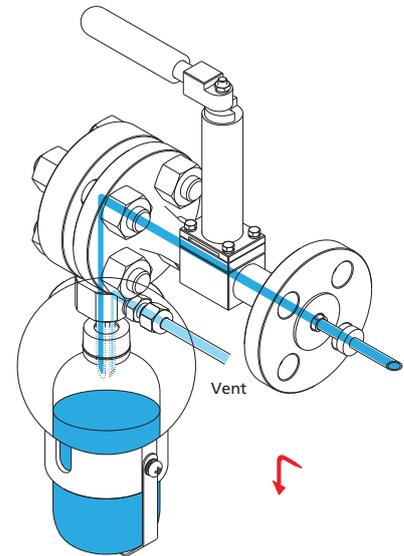

3 - Off

Remove the bottle retaining clip and take out the bottle from the sleeve. The septum reseals automatically to complete the sampling process.

